

SECTION A-A

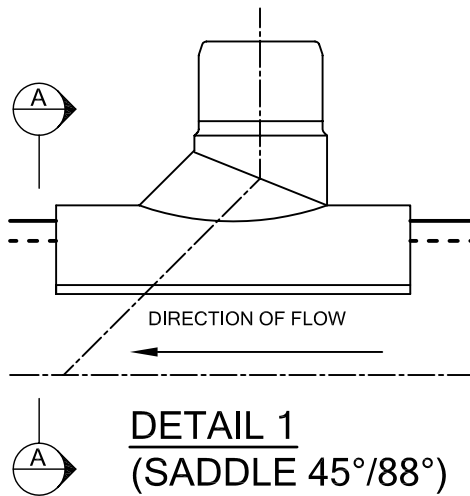

**DETAIL 1
(SADDLE 45°/88°)**

NOTES:

1. ALL DIMENSIONS ARE IN MILLIMETRES UNLESS STATED OTHERWISE
2. A ROAD OPENING PERMIT IS REQUIRED FOR ALL CONNECTIONS TO COUNCIL DRAINS
3. ALL PIPES ARE TO BE BEDDED ON 75mm DEPTH OF 20mm CLASS 2 CRUSHED ROCK OR QUARTER MINUS
4. CONNECTIONS TO COUNCIL DRAINS SMALLER THAN Ø300 ARE TO BE MADE USING A MANUFACTURED T-PIECE (FOR ALL NEW CONSTRUCTION OR WHERE PIPE IS PVC)
5. ALL TRENCHES UNDER PAVING AND BEHIND KERB & CHANNEL ARE TO BE BACKFILLED WITH 20mm CLASS 2 CRUSHED ROCK, COMPACTED IN 150mm LAYERS
6. EXISTING AGRICULTURAL DRAINS BEHIND THE KERB & CHANNEL ARE TO BE REINSTATED IF DAMAGED
7. HOUSE DRAIN CONNECTIONS ARE TO BE CONSTRUCTED AT RIGHT ANGLES TO THE EXISTING COUNCIL DRAIN

AMENDMENTS	DATE		HOUSE DRAIN CONNECTION WITHIN ROAD RESERVE	DRAWN BY: WDA
ORIGINAL - WDA	8/97			MANAGER CIVIL DEVELOPMENT SERVICES
UPDATED NOTES & DETAILS	1/07		SCALE: N.T.S.	
			DRAWING NO.: SD / H1	