

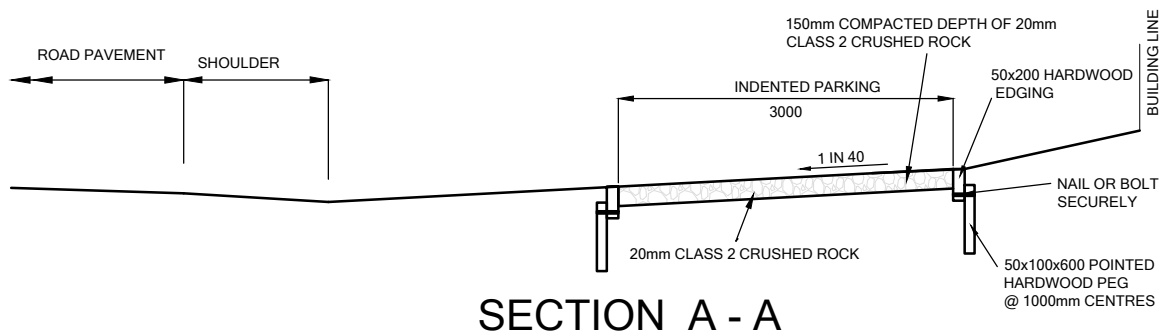

## ADJACENT TO CROSSOVER CROSSING PLAN



## SECTION A - A

**NOTES:**

1. ALL DIMENSIONS ARE IN MILLIMETRES UNLESS STATED OTHERWISE
2. NOT FOR TRUCK PARKING - PASSENGER VEHICLE ONLY.
3. A MINIMUM 2000mm CLEAR SPACE FOR FUTURE FOOTPATH AND SAFE PEDESTRIAN ACCESS MUST BE MAINTAINED.
4. A MINIMUM 5000mm SPACE LENGTH TO ACCOMMODATE A SINGLE CAR CLEAR OF DRIVEWAY.
5. A WIDER EXISTING DRIVEWAY WILL REQUIRE SMALLER SPLAY.
6. ROAD RESERVE WORKS PERMIT IS REQUIRED.
7. THE CONTRACTOR IS TO VERIFY THE LOCATION & DEPTH OF ALL UTILITY SERVICES PRIOR TO CARRYING OUT WORKS BY DIALLING 1100 'DIAL BEFORE YOU DIG'
8. A PLANNING PERMIT MAY BE REQUIRED FOR REMOVAL OF VEGETATION.
9. APPROVAL OF INSTALLATION IS SUBJECT TO AN ASSESSMENT OF TRAFFIC VISION AND SAFETY.
10. OWNER RESPONSIBLE FOR ONGOING MAINTENANT
11. COUNCIL WILL NOT ENFORCE EXCLUSIVE PARKING RIGHT.
12. ARRANGEMENT AS DETAILED CAN SERVE THE PURPOSE OF A THREE POINT TURN AROUND BAY.

AMENDMENTS	DATE		<b>ON STREET INDENTED PARKING BAY (CRUSHED ROCK) (WIDE NATURESTRIP)</b>	DRAWN BY: <b>PH</b>
				DATE: <b>FEB' 16</b>
				SCALE: <b>N.T.S.</b>
				DRAWING NO.:
				<b>SD / C8</b>
				MANAGER INFRASTRUCTURE SERVICES

*AMZ*